

SINGLE PHASE SYSTEMS 1.75kVA to 16.7kVA

Designed with Industry
Leading Footprint

Compatible with All
Lighting & Motor Loads



Cabinet depicted is 5kVA. Dimensions shown on chart.

STANDARD FEATURES

- 98% Efficient Typical
- Automatic Event, Test, and Alarm Log
- User Programmable With Password Protection
- Input Circuit Breaker
- RS232 Communications Port
- Space-Saving Design
- No Break 2ms Transfer Time
- NFPA 101 Self Testing and Data Logging
- Code Compliant : 90 Min. Runtime
- 65 KAIC Input Rating
- NEMA Type 1 Cabinet

OPTIONAL FEATURES

- Enhanced Communications
 - Expanded Building Management Protocols
 - BACnet or Modbus Communications Interface
 - NEW IoT Connect Cloud Software
- Internal or External Maintenance Bypass
- Summary Alarm
- Output Circuit Breakers
- Status Monitoring & Summary Form C Contacts
- Normally Off Output with Time Delay
- Output Trip Alarms
- Seismic
- Factory Startup & Training
- Extended Maintenance & Factory Warranty

SPECIFICATIONS

- Input Voltage: 120 or 277VAC | 1-Phase 2-Wire Plus Ground
- Output Voltage: 120 or 277VAC | 1-Phase 2-Wire Plus Ground
- Output Load Power Factor .5 Lag to .5 Lead
- Output Voltage Distortion Less Than 3% THD for Linear Loads
- Custom Voltage Available (Contact Factory)
- Forced Air Cooling Only During Emergency Operation; No Filters Required
- Compatible with All Lighting and Motor Loads
- Generator Compatibility
- 90 Minute Runtime Standard; Extended Runtimes Available upon Request
- Inverter Operating Temperature 32°F to 104°F (0°C to 40°C)
- Battery Operating Temperature 68°F to 86°F (20°C to 30°C) per UL 924 Specifications

BLI-I

Emergency Lighting Inverter

Single Phase Systems 1.5kVA/kW to 16.7kVA/kW



ORDERING GUIDE

EXAMPLE MODEL # 1-BLI-5-S-BA2007-F-2YW

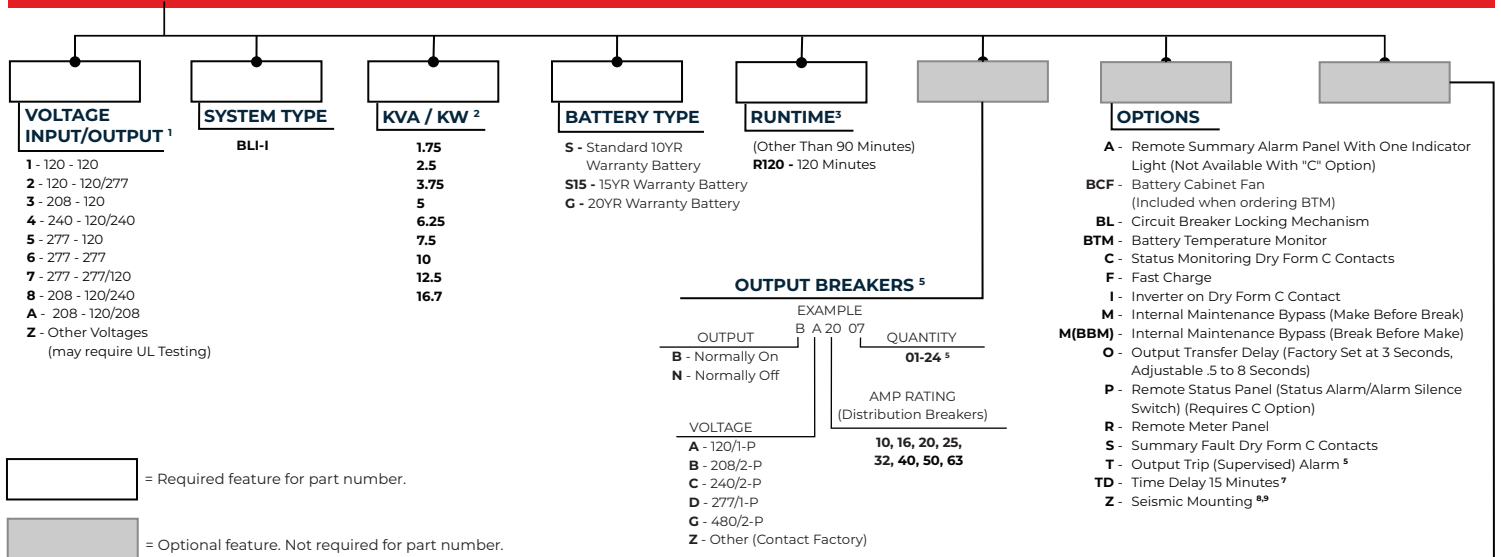

ACCESSORIES

- DT - Drip Top (NEMA 2)
- EMBP - External Maintenance Bypass Switch^A
- SPARES - Spare Fuses & Circuit Boards
- SPAREF - Spare Fuses

A) With External Maintenance Bypass Switch, only main output breaker is available.

- Only single phase voltages available.
- kVA= kW
- Standard battery runtime is 90 minutes. Contact factory for other runtimes. 120-minute run time is not available for 16.7kVA systems.
- Normally off loads cannot exceed 20% of total kVA rating with any combination of HID loads.
- Maximum output breakers available:
 1.75kVA-5kVA: 16 unsupervised (1-pole); or 11 supervised (1-pole)
 6.25kVA-7.5kVA: 24 unsupervised (1-pole); or 16 supervised (1-pole)
 10kVA-16.7kVA: 33 unsupervised (1-pole); or 22 supervised (1-pole)
 *Breakers are 20 Amps unless otherwise specified. A 2-pole breaker occupies 2 positions.
- One year warranty is standard.
- Time delay of normally off circuit will stay activated 15 minutes after return of utility.
- Anchorage based on calculations. For systems requiring OSHPD/Withstand testing, see Illuminator E-H.
- Contact factory for detailed seismic mounting drawing.

WARRANTY & ONSITE SERVICES⁶

- 2YW** - Start Up & Same Day Training (Increases Standard 1 Year Electronics Warranty to 2 years)
- 2YWT** - Start Up, Same Day Training and Full Run Test (Increases Standard 1 Year Electronics Warranty to 2 years)
- 5YP** - 5-Year Maintenance Plan
- 5YW** - 5-Year Extended Electronics Warranty (Includes 3 Years of Extended Electronics Warranty When Combined With 2YW)
- TR** - Training (if Required on Day Other Than Start Up)

DIMENSIONS

Alternate runtimes may affect cabinet size - contact factory.

Electronics Module									Batteries 90 Minutes @ Full Load				Total System Weight (lbs / kg)
Partial Model Number	Power Rating (kVA / W)	Efficiency (Typical Percent)	Audible Noise (db)	Heat Loss (BTU)	Cabinet Dimensions*				90 Minutes Batteries (lbs / kg)	Number of Batteries	Voltage (VDC)	Current (amps)	
					Width (in / cm)	Height (in / cm)	Depth (in / cm)	Weight (lbs / kg)					
BLI-I-1.75	1.75	98	45	119	24 / 61	48 / 122	25 / 64	247 / 112	320 / 145	4	48	46	567 / 257
BLI-I-2.5	2.5	98	45	170	24 / 61	48 / 122	25 / 64	343 / 156	400 / 181	4	48	66	743 / 337
BLI-I-3.75	3.75	98	45	255	24 / 61	48 / 122	25 / 64	400 / 181	600 / 272	6	72	66	1000 / 454
BLI-I-5	5.0	98	45	340	24 / 61	48 / 122	25 / 64	457 / 207	800 / 363	8	96	66	1257 / 570
BLI-I-6.25	6.25	98	45	425	36 / 91	53 / 135	25 / 64	618 / 280	1000 / 454	10	120	66	1618 / 734
BLI-I-7.5	7.5	98	45	510	36 / 91	53 / 135	25 / 64	684 / 310	1200 / 544	12	144	66	1884 / 855
BLI-I-10	10.0	98	45	680	42 / 107	78.3 / 199	25 / 64	964 / 437	1440 / 653	12	144	88	2404 / 1090
BLI-I-12.5	12.5	98	45	850	42 / 107	78.3 / 199	25 / 64	1010 / 458	1800 / 816	15	180	88	2810 / 1275
BLI-I-16.7	16.7	98	45	1136	42 / 107	78.3 / 199	25 / 64	1070 / 485	2400 / 1089	20	240	88	3470 / 1574