

**For Switched and 0-10V Dimmable (-D) Loads**

Project: \_\_\_\_\_

Model No.: \_\_\_\_\_

Comments: \_\_\_\_\_



**MOUNTING**

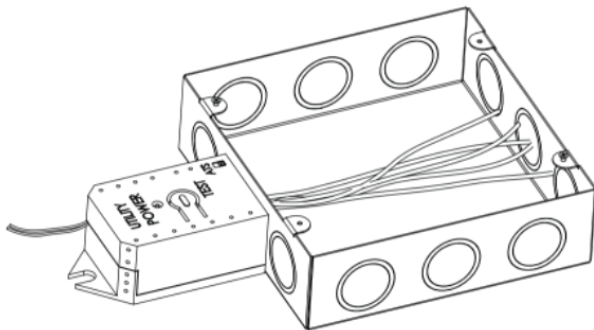

**APPLICATION**

In the past, emergency lights were kept on 24 hours a day to meet life safety codes. Now, you can use a UL 924 listed Emergency Power Control, Model BL2-EPC-A-2 and BL2-EPC-A-2-D (for 0-10V dimmable loads), to convert normal light fixtures into approved emergency lights, saving energy and money while ensuring compliance with both life safety and energy codes.

During normal operation, the same switch, occupancy sensor, relay panel, or lighting control can switch normal and emergency fixtures on and off simultaneously.

During a utility power interruption, the BL2-EPC-A-2(-D) automatically bypasses normal lighting controls, turning the emergency lights ON, regardless of switch position. The device is knock-out mounted and is usually located in the area where the emergency fixtures are installed.

**FEATURES**

- Unique, Patented Automatic Diagnostic  
When the room switch is turned off, the BL2-EPC-A-2(-D) will run a 2.5 self-test. This feature eliminates the need for time-consuming and costly manual monthly testing and is approved for this purpose. This also allows the unit to be installed in remote or inaccessible locations, because the unit does not rely on access to its manual test switch.  
*To disable this feature, toggle "ATS" slide switch*
- Fire Alarm, Remote Test
- Utility Power Indicator LED's
- Easy to install plastic threaded nipple allows mounting to 1/2" Knockout on junction box or light fixture. Mounting ears allow installation on single gang ring or in panel.

# SINGLE LINE DRAWING

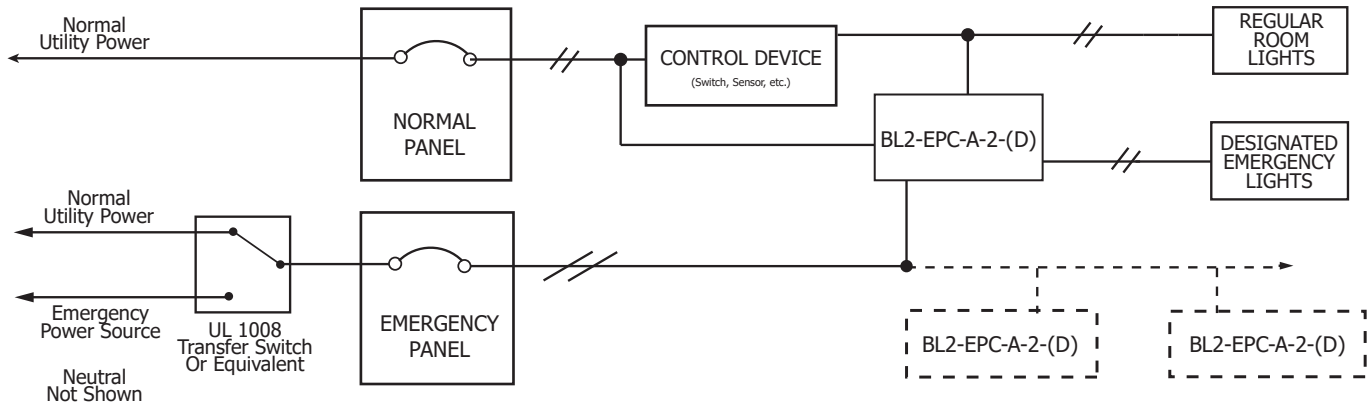

# WIRING DIAGRAM

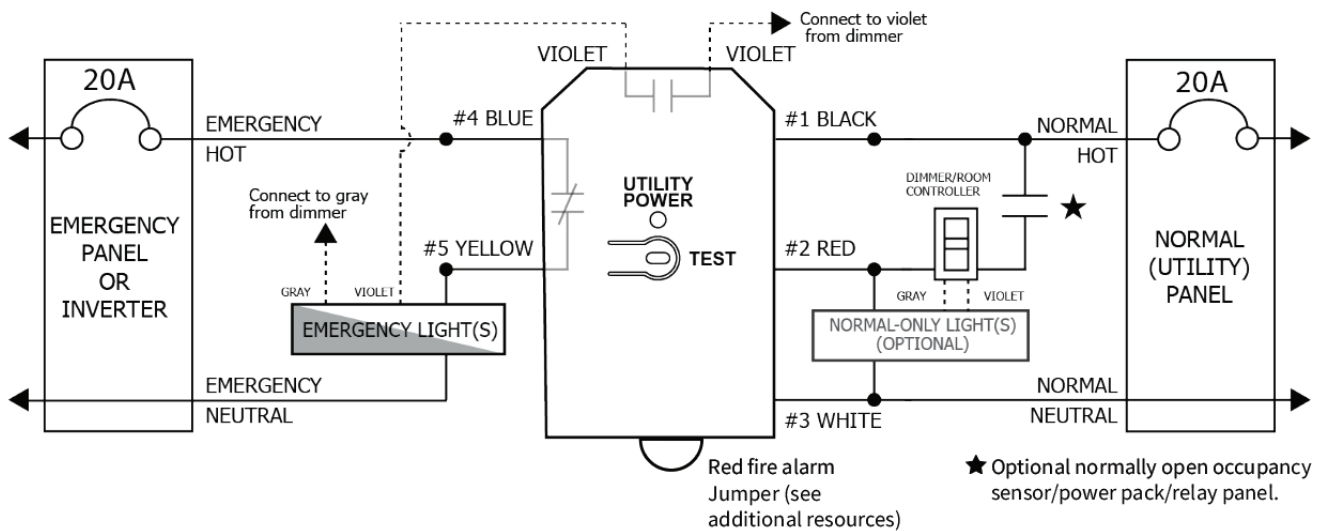

# SPECIFICATIONS

ELECTRICAL	MODEL NO.	BL2-EPC-A-2(-D)	MECHANICAL	MOUNTING	Mounts on 1/2" Knockout
	SENSING INPUT	120V - 277V		RATING	UL94-5VA
	LOAD RATING	120V - 277V (16A)		SHIPPING WEIGHT / COLOR	4 oz. / Black
	BALLAST LOAD RATING	16A Electronic, 5A Magnetic		TEMPERATURE	32°F - 140°F (0°C - 60°C)
	INCANDESCENT LOAD	1800W (120V) / 3000W (277V)		BODY SIZE (with ears)	3-5/8" x 1-5/8" x 1-3/8"
	WARRANTY	5 Year Replacement Warranty		BODY SIZE (without ears)	2-1/2" x 1-5/8" x 1-3/8" x D body

# ORDERING INFORMATION

BL2-EPC-A-2 for Switched Loads  
 BL2-EPC-A-2-D for 0-10V Loads

# ADDITIONAL RESOURCES

- Installation Sheet
- FAQ Sheet
- Alternative Wiring Sheet
- Terms & Conditions/Warranty Information

BL2 Systems LLC. 2555 Nicholson Street, San Leandro, CA 94577-4216  
 612-408-1550 quotes@BL2Systems.com  
 www.BL2Systems.com