



WIRELESS WIDEVIEW & HALLWAY OCCUPANCY SENSOR

BATTERY POWERED

OVERVIEW

The **BL2 SYSTEMS** wireless wide view and hallway occupancy sensors are a simple, yet reliable battery powered control solution. Preferred by contractors for their flexible mounting methods, **BL2 SYSTEMS** wireless sensors greatly reduce total installation time and wireless pairing fuss. Requiring just a few seconds per device, **BL2 SYSTEMS** wireless sensors can be linked to one or more wireless load controllers (such as the **BL2-851** wireless wall switch, or a **BL2-950** series wireless power pack). Additionally, these sensors can be configured to work in applications with other wireless or wired ceiling, corner, or hallway sensors to provide extended coverage in large or irregularly shaped spaces. As with all **BL2 SYSTEMS** products, the latest passive infrared technology and techniques are used to provide unmatched occupant detection performance and energy savings. Additionally, wideview units are available with an integrated microphone to provide overlapping passive acoustic detection for rooms with obstructions or where occupant motion is limited.

BASIC OPERATION

Sensors detect movement in the infrared energy that radiates from occupants as they move within the device's field-of-view. Once occupancy is detected, the sensor immediately signals a wirelessly linked load controller (e.g. power pack) to switch on or dim up the connected lighting. If equipped with passive dual technology (PIR/Acoustic), the units microphone is then also enabled to further enhance detection while the lights are on. At regular intervals, the sensor will retransmit its latest occupancy status such that the load controller can keep lights on for occupants during brief periods of inactivity, while returning the space to an energy saving lights off (or dim) state once no longer occupied.



FEATURES

- Pairs in Seconds with Wireless Controllers
- Passive Infrared (PIR) Detection
- Passive Dual Technology (PIR/Acoustic) Detection (Optional)
- Wide View or Hallway (Long Range) Coverage Pattern Options
- Compact Size and Matte Finish
- Five Contractor Friendly Mounting Methods
- Mounting Nipple Attachment with Integrated Hole Saw
- Convenient Test Mode

SPECIFICATIONS

ELECTRICAL & WIRELESS

BATTERY TYPE

Requires one CR123(A) Lithium Battery

BATTERY LIFE

PIR Model - Designed for 10 yr.
Dual Tech. Models - Designed for 5 yr.
Non-Volatile Memory (saves all settings regardless of battery state)
Blink Warning @10% Life

RANGE

80' line of site w/o obstruction (walls)
40' with obstruction (walls/floors)

FREQUENCY

915 MHz ISM Band

WIRELESS LINKING

Simple 3 sec. Push Button Process

SECURITY

All Wireless Data is Encrypted

ENVIRONMENTAL

OPERATING TEMP

32°F to 122°F (0°C to 50°C) - Standard
-40° F/C (with -HE Option)

RELATIVE HUMIDITY

0-95% Non-Condensing,
Indoor Use Only

CODE COMPLIANCE

These sensors can be used to meet ASHRAE 90.1, IECC, & Title 24 energy code requirements.

PHYSICAL

SIZE

2.875" H x 2.75" W x 3.25"D
(7.30 x 6.98 x 8.25 cm)

WEIGHT

4.75 oz.

COLOR

White

LED INDICATION

Occupant Detection (in Test Mode only)
Wireless Linking (Pairing)

OPERATION

OPERATING MODES

Occupancy & Vacancy Modes -
Configured on Linked Controller

COMPATIBLE LOAD CONTROLLERS

BL2-851 Wall Switch
BL2-950 Series Power Packs

WIRELESS TEST MODE

Button Toggles On/Off
Wirelessly Linked Loads

COVERAGE TEST MODE

LED Blinks to Indicate Occupancy

TIME DELAY OPTIONS

Configured at Load Controller(s)
1, 5, 10, 15, 20, 30 min.



ORDERING INFO

MODEL NUMBER	DESCRIPTION
BL2-401-B	Wireless Wide View 120° Sensor, PIR, Battery Powered
BL2-421-B	Wireless Dual Technology Wideview 120° Sensor, PIR/Acoustic, Battery Powered
BL2-402-B	Wireless Hallway Sensor, PIR, Battery Powered

OPTION

- **HE** - High Humidity Environment

APPLICATIONS

A single wireless wide view sensor provides an excellent solution for a medium sized space like a conference room or small classroom. However, multiple wireless sensors can be easily linked to the same load controller(s) to provide coverage for larger spaces like an open office or large classroom. Dual Technology sensors are recommended in spaces where people are seated and/or where obstructions like cubicle walls block line of site to the sensors. The wireless hallway sensor provides excellent coverage of hallways from one or both ends.

Additionally, when linked to wireless wall switch load controllers (**BL2-851**) or to wireless power packs (**BL2-950** Series) and remote wireless wall stations, these sensors can be used to meet ASHRAE 90.1, IECC, & Title 24 energy code requirements that require vacancy operation.

- Classrooms
- Conference Rooms
- Break Rooms
- Open Offices
- Hallways

COVERAGE PATTERN

PASSIVE INFRARED (PIR)

WIDE VIEW 120°

- Small motion (e.g., hand movements) detection up to 40 ft (12.19 m)
- Large motion (e.g., walking) detection up to 70 ft (21.34 m)
- Designed for 8 to 12 ft (2.44 to 3.66 m) high mounting

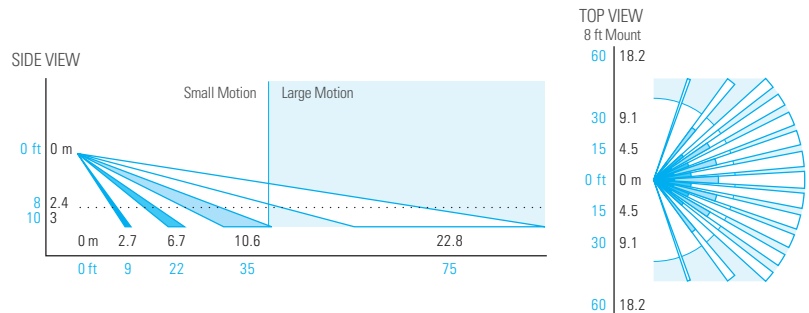
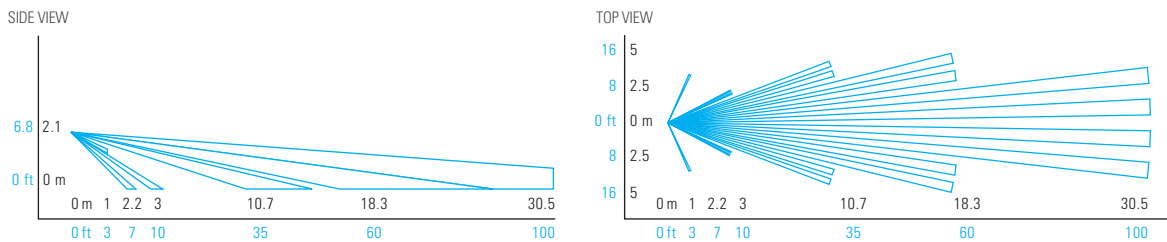

Diagram reflects sensor in first position. Adjust angle downward if mounting above 10 feet or to decrease gap directly under sensor.

HALLWAY (LONG RANGE)

- Designed for 8 to 12 ft (2.44 to 3.66 m) high mounting
- Large motion (e.g., walking) detection up to 100 ft (30.48 m)
- Detection occurs sooner when crossing coverage beams upon entry to a hallway as opposed to entering from the end and walking directly at the sensor



DUAL TECHNOLOGY (PIR/ACOUSTIC)

- Units with dual technology (**BL2-421-B**) have overlapping acoustic detection of the complete PIR coverage area.
- A PIR event is required to initially enable acoustic detection.
- Sounds indicating occupancy reset the sensor's time delay while non-occupant noises are filtered out. Occupant sounds alone will not keep lights on indefinitely, PIR motion must be periodically detected for lights to remain on for an extended time.
- After sensor time out expires, acoustic detection remains enabled for 15 seconds to enable voice reactivation of lights for additional convenience and safety.

OPERATION NOTES

- Wireless sensors periodically transmit their PIR and/or acoustic (if equipped) occupancy status. Referred to as the sensor's "heartbeat", this period is optimized to conserve battery life.
- If a sensor transmitted "unoccupied" at its last heartbeat, any new PIR detection event will be transmitted immediately.
- Using the information received from linked sensors, wirelessly linked load controllers switch lighting accordingly.
- All load controllers have a master time delay that is initially set only when a PIR occupancy transmission is received from a linked sensor. The time delay will then be reset every time a sensor reports any occupancy (either PIR or acoustic). Lights will be switched off once all linked sensors have continuously reported unoccupied for the duration of the time delay.
- To prevent lights from staying on indefinitely from just acoustic events, after ~30 minutes the load controller will stop considering acoustic events from all linked sensors until after a PIR event is received again.
- As an added safety measure after lights are switched off, acoustic detection remains enabled for 15 seconds to enable voice reactivation of lights.
- If a load controller does not receive any heartbeat transmissions from a linked sensor for 10 minutes it will blink out an error code (4 blue blinks, followed by a pause) and consider itself occupied (so as to override the lights on). If more than one sensor is linked, the sensor heartbeats from all sensors must have stopped for the error warning to begin blinking.

BATTERY INFORMATION

- The sensor runs on one CR123(A) Lithium Battery (included).
- Install battery prior to mounting sensor. Polarity is indicated on the battery compartment door.
- 10 year battery life design for PIR only models. For dual technology units with acoustic detection enabled, expected battery life is 5 years.
- If the sensor's battery life reaches 10%, all wirelessly linked load controllers will blink lights on/off/on upon initial occupancy as a replacement warning.
- Replacement batteries are available at most retailers or home centers where batteries are sold or from **BL2 SYSTEMS**.

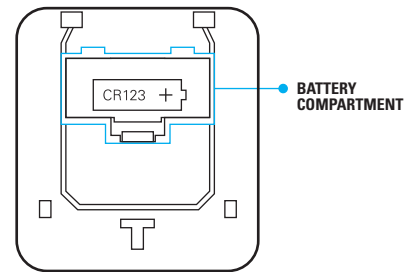

INSTALLATION OPTIONS

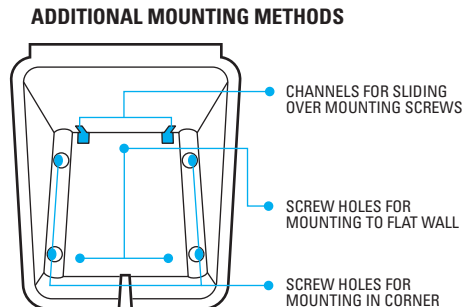
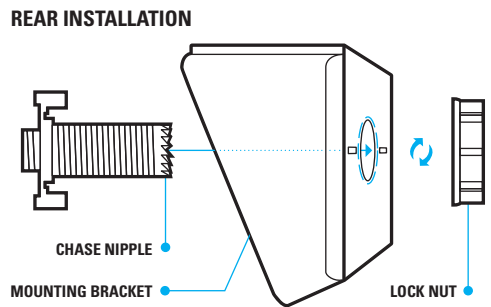
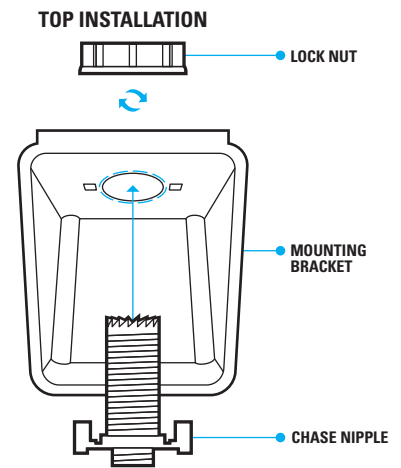
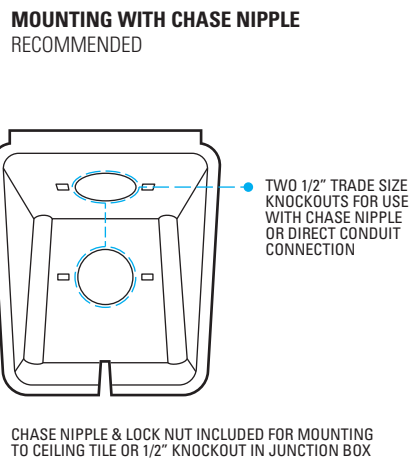
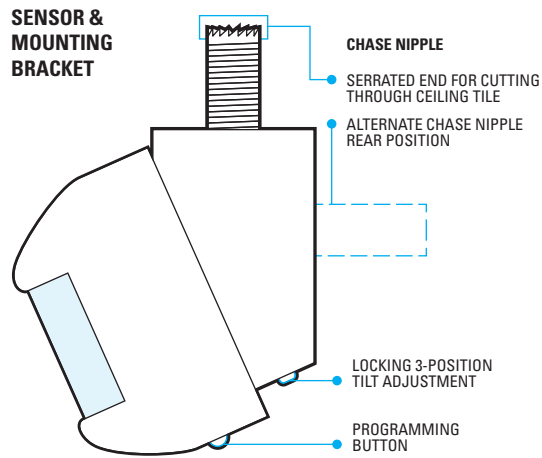

COMPATIBLE WIRELESS DEVICES

The below chart lists the devices that can be used in a **BL2 SYSTEMS** wireless application. Note that sensors and remote switch & dimmer devices are transmit only devices and therefore must be linked to a load controller for switching or dimming of lighting.

MODEL #	DESCRIPTION	WIRELESS TYPE	POWER TYPE
BL2-201-B	Small Motion 360° Sensor, PIR	Transmit	Battery
BL2-211-B	Small Motion 360° Sensor, PIR w/ Integrated Daylight Harvesting Photocell	Transmit	Battery
BL2-221-B	Dual Technology Sensor (PIR/Acoustic), Small Motion 360°	Transmit	Battery
BL2-401-B	Wide View Sensor, PIR	Transmit	Battery
BL2-421-B	Dual Technology (PIR/Acoustic) Wide View Sensor	Transmit	Battery
BL2-402-B	Long Range Hallway Sensor, PIR	Transmit	Battery
BL2-250-B	Daylight Harvesting & On/Off Photocell	Transmit	Battery
BL2-851-xx	Wall Switch Load Controller, No Neutral Required, <xx = color>	Transmit & Receive	120-277 VAC
BL2-852-B-xx	Remote Switch (On/Off), <xx = color>	Transmit	Battery
BL2-852-2-xx	Remote Line Powered Switch (On/Off), <xx = color>	Transmit	120-277 VAC
BL2-854-B-xx	Remote Dimming Switch (On/Off, Raise/Lower), <xx = color>	Transmit	Battery
BL2-854-2-xx	Remote Line Powered Dimming Switch (On/Off, Raise/Lower), <xx = color>	Transmit	120-277 VAC
BL2-874-ELV-xx	Phase Dimming Load Controller - Reverse (default) or Forward Phase, <xx = color>	Transmit & Receive	120 VAC
BL2-950	Power Pack Load Controller, 20A	Transmit & Receive	120/277 VAC
BL2-951-D1	Fixture Controller, 1A@, 0-10V Dimming	Transmit & Receive	120-277 VAC
BL2-950-D2 (BL2-950-D1)	Power Pack Load Controller, 20A, 0-10V Class 2 Dimming (Class 1 model)	Transmit & Receive	120/277 VAC
BL2-950-AX	Hybrid Wireless/Wired Power Pack Load Controller, 20A	Transmit & Receive	120/277 VAC
BL2-950-AX-D2	Hybrid Wireless/Wired Power Pack Load Controller, 20A, 0-10V Dimming	Transmit & Receive	120/277 VAC

WIRELESS LINKING (PAIRING)

Linking a sensor with a wall switch controller or power pack is quickly done via the following procedure:

1. Enter pairing mode by holding down the wall switch controller's (or power pack's) button for 3 seconds until the LED starts alternating white then blue, then release.
2. At the sensor, hold down the programming button for 3 seconds until the LED starts alternating white then blue. Releasing will link the sensor with any device in pairing mode (see note 1 below). The lights will toggle once as confirmation.
3. Repeat step 2 to link another sensor or device.
4. When all devices have been linked, close pairing mode on the wall switch controller (or power pack) by pressing the button 1 time. Pairing will also be automatically closed after 15 minutes of no new devices being linked.

Note 1: When in pairing mode, the alternating LED colors on the wall switch controller (or power pack) will periodically pause and blink out the total number of linked devices. There will be no blinks during the pause until the first device is linked.

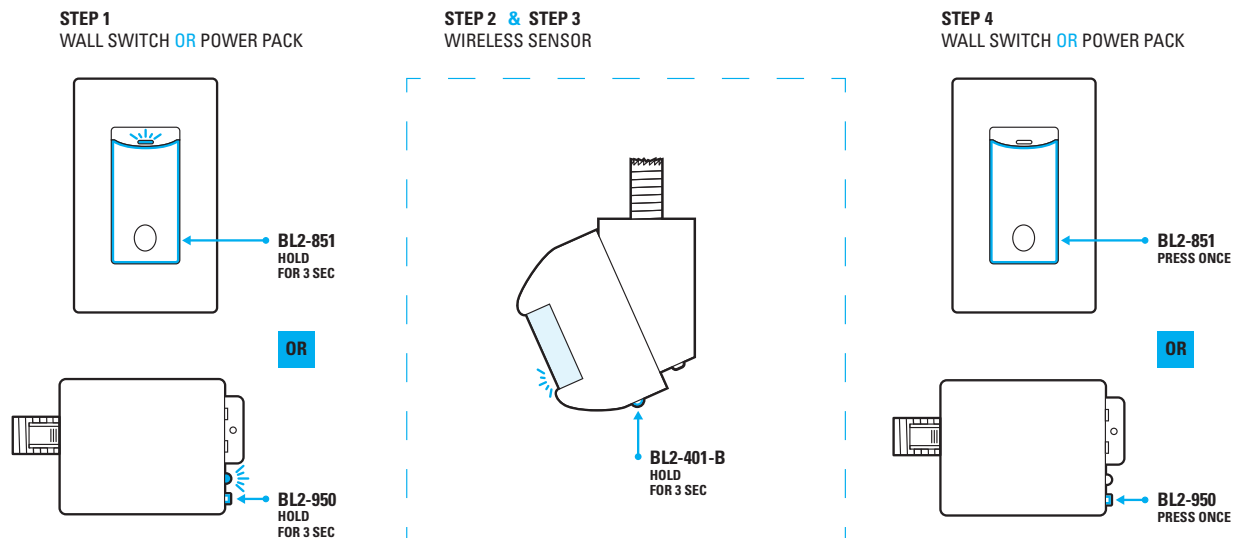

FCC INFORMATION (FCC ID: 2AVRY-SWX0002)

This device complies with Part 15 of the FCC Rules. Operation is subject to the following conditions:

1. This device may not cause harmful interference, and
2. This device must accept any interference received, including interference that may cause undesired operation

Changes and Modifications not expressly approved by BLP Technologies can void your authority to operate this equipment under Federal Communications Commission's rules.

INDUSTRY CANADA INFORMATION (IC: 26012-SWX0002)

This device complies with Industry Canada license-exempt RSS standard(s). Operation is subject to the following two conditions: (1) this device may not cause interference, and (2) this device must accept any interference, including interference that may cause undesired operation of the device.

Le présent appareil est conforme aux CNR d'Industrie Canada applicables aux appareils radio exempts de licence. L'exploitation est autorisée aux deux conditions suivantes : (1) l'appareil ne doit pas produire de brouillage, et (2) l'utilisateur de l'appareil doit accepter tout brouillage radioélectrique subi, même si le brouillage est susceptible d'en compromettre le fonctionnement.

