



WIRELESS PHASE DIMMING LOAD CONTROLLER

LINE VOLTAGE



OVERVIEW

The **BL2 SYSTEMS** wireless phase dimming load controller links to remote occupancy sensors, photocells, and companion switches without low voltage wiring in order to provide both manual and automatic lighting control. With no minimum load requirements, this dimmer is perfect for even the smallest lighting zone. Additionally, at less than one inch deep, the unit is significantly shallower than typical dimmers. This results in less crowded wall boxes and quicker installation. All **BL2 SYSTEMS** products are proudly made in the USA.

FEATURES

ELECTRICAL FEATURES

- Dims LED, CFL, ELV, & Incandescent Lighting Loads
- Selectable Reverse (default) and Forward Phase Dimming in Same Unit
- No Minimum Load Ratings - Relay Based Switching
- 3-Way+ Dimming when Wirelessly Linked with Remote Dimming Stations
- Overload Protection Monitors & Protects Unit from Overheating

PHYSICAL FEATURES

- Enclosure is 25-40% Shallower than Other Wall Dimmers (< 1" Depth into Wallbox)
- Modern Look and Individual Easy-Tap Buttons for On, Off, Raise, & Lower
- Matches Styling of other BL2 Wall Devices
- Self-Grounding Mounting Strap
- Blue Locator LED when Lights are Off

OPERATIONAL FEATURES

- Links in Seconds with Wireless Sensors & Remote Wall Stations
- Configurable Dimming Parameters including High/Low Trims, Turn on Levels, and Curve Types
- Configurable Time Delays and Operational Modes (e.g. Occupancy, Vacancy, Partial On, Partial Off) when Linked to Wireless Sensors
- Configurable Daylight Harvesting & Photocell Modes when Linked to Wireless Photocells
- Settings are Adjustable without Removing Cover Plate
- Links with up to 30 Wireless Devices
- White LED Indicator Changes Intensity as Dim Level is Adjusted

SPECIFICATIONS

ELECTRICAL

OPERATING VOLTAGE

120VAC, Single Phase, 50/60 Hz

MAX LOAD RATINGS

In Reverse Phase Mode (default)

375W LED / ELV

375W Incandescent/Halogen

In Forward Phase Mode (optional)

150W CFL / LED

Consult factory for MLV rating

MIN LOAD RATINGS: None

LOAD TYPES

Electronic Low Voltage

LED Driver/Lamps

CFL, Electronic/Magnetic Ballasts
(Fluorescent)

Tungsten (Incandescent)

Halogen

MLV (consult factory)

ESD IMMUNITY

Tested to withstand electrostatic discharge without damage or memory loss.

SURGE IMMUNITY

Tested to withstand surge voltages without damage or loss of operation.

NON-VOLATILE MEMORY

Saves all settings even if power is disrupted.

OPERATION

OPERATING MODES

Occupancy & Vacancy,

Partial On/Off

Daylight Harvesting

On/Off/Inhibit Photocell

TIME DELAY OPTIONS

1, 5, 10, 15, 20, 30 min.

WIRELESS

RANGE

80' line of site w/o obstruction (walls)
40' with obstruction (walls/floors)

FREQUENCY

915 MHz ISM Band

WIRELESS LINKING

Simple 3 sec. Push Button Process

SECURITY

All Wireless Data is Encrypted

ENVIRONMENTAL

OPERATING TEMP

32°F to 86°F (0°C to 30°C) - Standard
(for full load operation)

-40° F/C (with **-HE** Option)

RELATIVE HUMIDITY

0-95% Non-Condensing
Indoor Use Only

PHYSICAL

SIZE

2.74"H x 1.68"W x 1.39"D

(6.96 x 4.27 x 3.53 cm)

<1" Wallbox Mounting Depth

WEIGHT

4.5 oz

MOUNTING

Single Gang Switch Box

LED STATUS INDICATOR

Bi-color White & Blue

CODE COMPLIANCE

These load controllers can be used to meet ASHRAE 90.1, IECC, & Title 24 energy code requirements.



ORDERING INFO

SAMPLE MODEL # BL2-874-ELV-WH

PRODUCT DESCRIPTION	COLOR*	OPTION	PACKAGE COUNT
BL2-874-ELV Wireless Dimming Load Controller, 120VAC - Reverse Phase (for Electronic Low Voltage/ LED/CFL/Incandescent/Halogen) or Forward Phase	White - WH Ivory - IV Light Almond - LA Gray - GY Black - BK	Low Temp / High Humidity - HE	Single Pack 10 Pack** Blank -J10

*WALLPLATE NOT INCLUDED

ACCESSORY PART #	COLOR*	PACKAGE COUNT
BL2-854-2 Wireless Line Powered Remote Dimming Wall Station (companion switch only - unit is not a load controller)	White - WH	Single Pack
BL2-852-2 Wireless Line Powered Remote On/Off Wall Station (companion switch only - unit is not a load controller)	Ivory - IV	10 Pack**
BL2-854-B Wireless Battery Powered Remote Dimming Wall Station (companion switch only - unit is not a load controller)	Light Almond - LA	Blank - J10
BL2-852-B Wireless Battery Powered Remote On/Off Wall Station (companion switch only - unit is not a load controller)	Gray - GY	
BL2-199 Single Gang Wall Plate	Black - BK	

** THE CONTRACTOR PACK OPTION (-J10) REDUCES JOB SITE WASTE AND INVENTORY TIME

APPLICATIONS

SMALL SPACES

For control of small spaces like a private office, a wireless phase dimmer controller linked to single wireless ceiling sensor (e.g. **BL2-221-B**) is recommended (see diagram on right). Both occupancy (auto-on) and vacancy (manual-on) operation are achievable in order to meet energy code requirements.

MEDIUM SIZE SPACES

For control of medium size spaces like a conference room or small classroom, a wireless phase dimmer controller linked to a single wireless wide view sensor (e.g. **BL2-421-B**) provides an excellent solution. Linking additional sensors is also an option if necessary. Dimming and/or switching from a second location (e.g. 3-way) is achieved by linking a remote wireless wall switch (either the line powered **BL2-854-2** or the battery powered **BL2-854-B**) to the wireless phase dimming load controller.

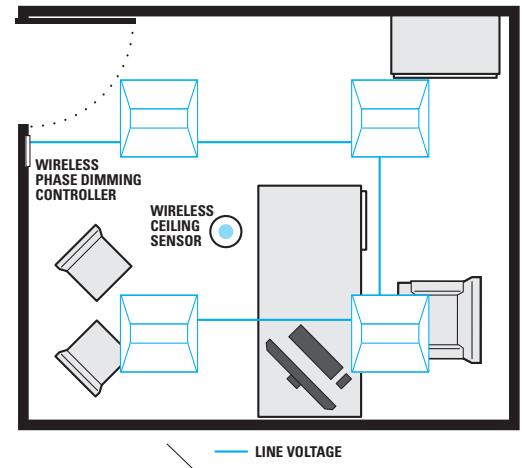

COMPATIBLE WIRELESS DEVICES

The below chart lists the devices that can be used in a **BL2 SYSTEMS** wireless application. Note that sensors, photocells, and remote switch devices are transmit only devices and therefore must be linked to a load controller for switching of lighting.

MODEL #	DESCRIPTION	WIRELESS TYPE	POWER TYPE
BL2-201-B	Small Motion 360° Sensor, PIR	Transmit	Battery
BL2-211-B	Small Motion 360° Sensor, PIR w/ Integrated Daylight Harvesting Photocell	Transmit	Battery
BL2-221-B	Dual Technology Sensor (PIR/Acoustic), Small Motion 360°	Transmit	Battery
BL2-401-B	Wide View Sensor, PIR	Transmit	Battery
BL2-421-B	Dual Technology (PIR/Acoustic) Wide View Sensor	Transmit	Battery
BL2-402-B	Long Range Hallway Sensor, PIR	Transmit	Battery
BL2-250-B	Daylight Harvesting & On/Off Photocell	Transmit	Battery
BL2-851-xx	Wall Switch Load Controller, No Neutral Required, <xx = color>	Transmit & Receive	120-277 VAC
BL2-852-B-xx	Remote Switch (On/Off), <xx = color>	Transmit	Battery
BL2-852-2-xx	Remote Line Powered Switch (On/Off), <xx = color>	Transmit	120-277 VAC
BL2-854-B-xx	Remote Dimming Switch (On/Off, Raise/Lower), <xx = color>	Transmit	Battery
BL2-854-2-xx	Remote Line Powered Dimming Switch (On/Off, Raise/Lower), <xx = color>	Transmit	120-277 VAC
BL2-874-ELV-xx	Phase Dimming Load Controller - Reverse (default) or Forward Phase, <xx = color>	Transmit & Receive	120 VAC
BL2-950	Power Pack Load Controller, 20A	Transmit & Receive	120/277 VAC
BL2-951-D1	Fixture Controller, 1A@, 0-10V Dimming	Transmit & Receive	120-277 VAC
BL2-950-D2 (-D1)	Power Pack Load Controller, 20A, 0-10V Dimming, Class 2 (Class 1)	Transmit & Receive	120/277 VAC
BL2-950-AX	Hybrid Wireless/Wired Power Pack Load Controller, 20A	Transmit & Receive	120/277 VAC
BL2-950-AX-D2	Hybrid Wireless/Wired Power Pack Load Controller, 20A, 0-10V Dimming	Transmit & Receive	120/277 VAC

WIRING

DIMMING FROM A SINGLE LOCATION

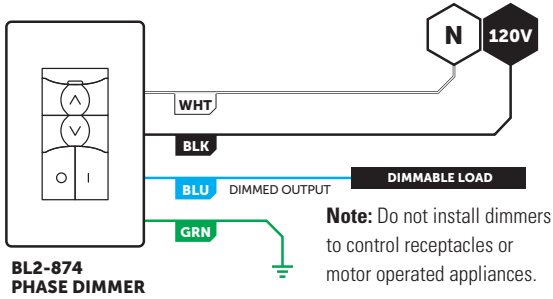

DIMMING FROM MULTIPLE LOCATIONS (e.g. 3-way) - OPTION 1

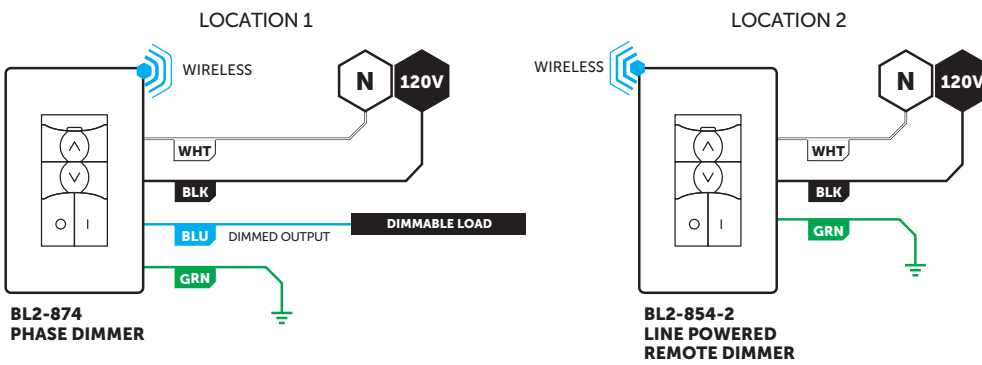

DIMMING FROM MULTIPLE LOCATIONS (e.g. 3-way) - OPTION 2

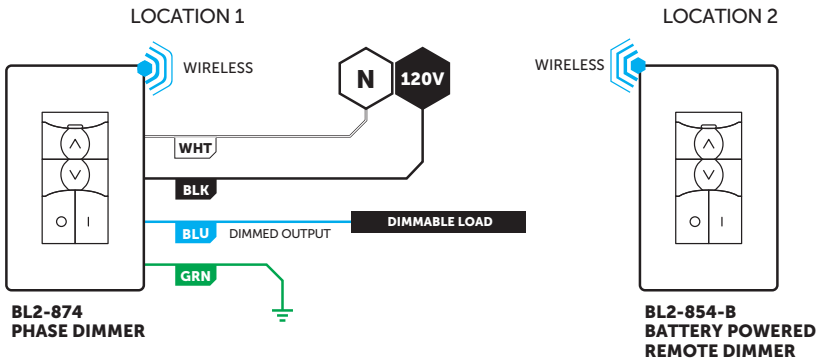

DIMMING FROM MULTIPLE LOCATIONS (e.g. 3-way) - OPTION 3

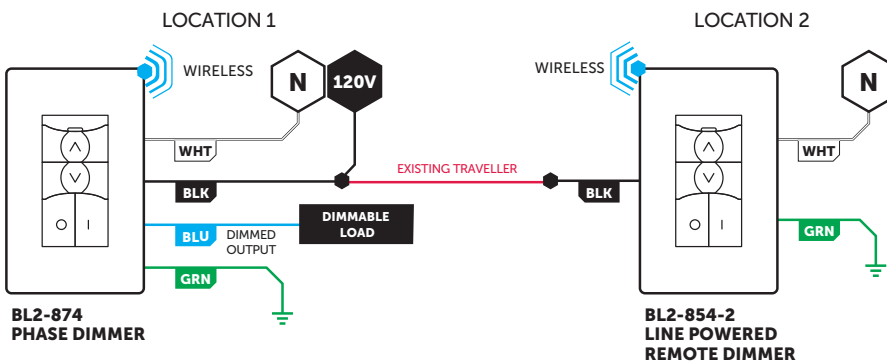

WIRELESS LINKING (PAIRING)

Linking a phase dimming load controller with a sensor, photocell, power pack, remote dimmer, or another wall switch controller is quickly done via the following procedure:

- Step 1.** Enter learn mode by holding down the phase dimmer's On button for 3 seconds until the LED starts alternating blue and white, then release.
- Step 2.** At the sensor (or other remote device), hold down the programming button for 3 seconds until the LED starts alternating blue and white. Releasing will link the sensor with the phase dimmer in learn mode (see note 1 below).
- Step 3.** Repeat step 2 to link another sensor or device.
- Step 4.** When all devices have been linked, exit learn mode on the phase dimmer controller by pressing the button 1 time. Learn mode will also be automatically closed after 15 minutes if no new devices being linked.

Note 1: Once a device(s) is linked, the alternating LED colors on the phase dimming controller will periodically pause and blink out total number of linked devices. There will be no blinks during the pause until after the first device is linked.

Note 2: Linking two wall switch controllers (or one wall switch controller and one wireless power pack) can be done by putting each device in learn mode first (i.e. Step 1 above) before continuing to Step 2 for each device. After Step 2 has been completed for each device, continue to Step 3 for each device.

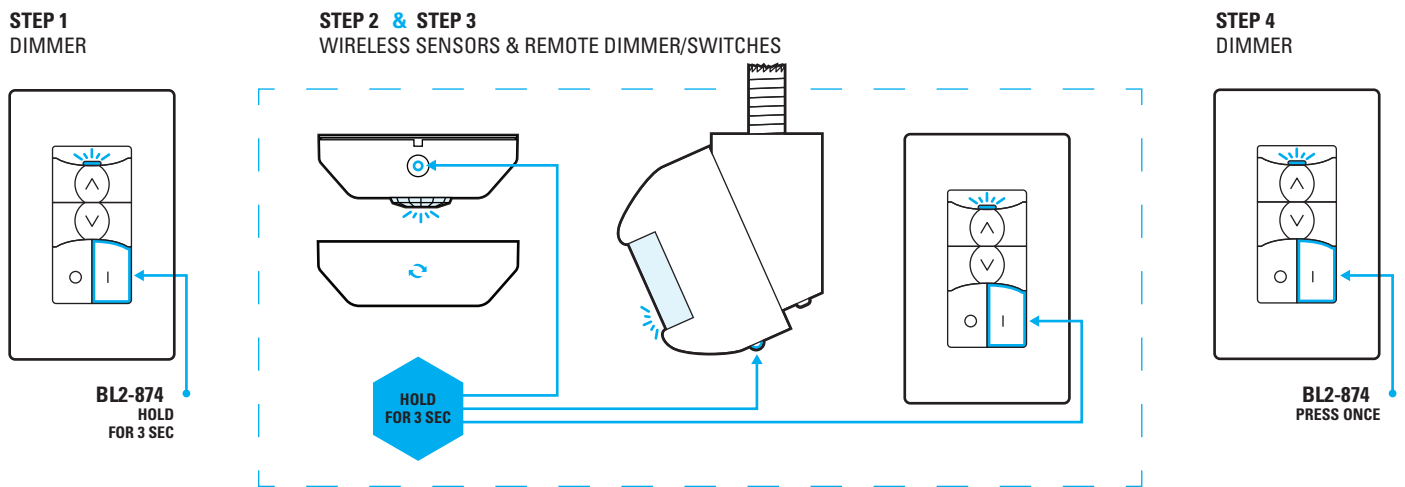

INSTALLATION

- Designed to mount in 1-gang wall box with 3.28" hole spacing.
- Units can also share multiple gang wall boxes with other devices.
- Unit face is field removable in order to change colors. Contact factory for additional faces.

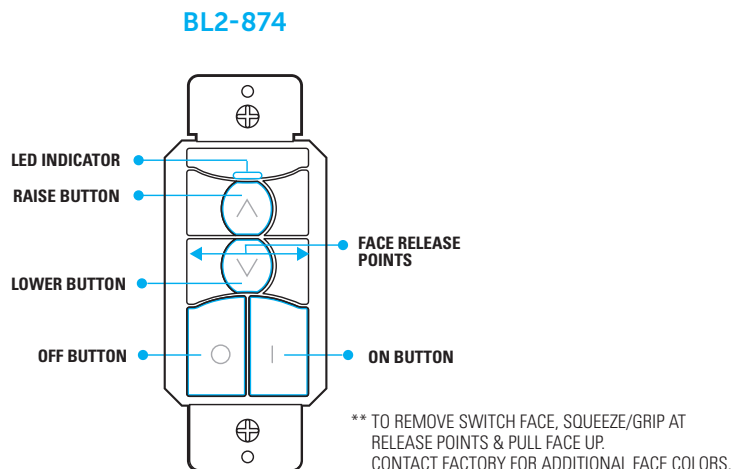

OPERATION NOTES

GENERAL WIRELESS OPERATION

- By default, every ~60 seconds wireless sensors transmit a status message whether or not occupancy was detected during the previous period.
- Referred to as the sensor's "heartbeat", this period can be reduced to ~30 seconds although this will decrease expected battery life.
- If a sensor transmitted "unoccupied" at its last heartbeat, any new occupancy detection event will be transmitted immediately.
- If a sensor transmitted "occupied" at its last heartbeat, new occupancy events will only be transmitted at the heartbeat interval, thus conserving battery life.
- All wirelessly linked wall switch load controllers and/or power packs have a master time delay that is reset every time a linked sensor reports occupancy. Lights will be switched off once all linked sensors have continuously reported unoccupied for the duration of the time delay.
- If a wall switch load controller does not receive a heartbeat transmission from a linked sensor for 10 minutes it will blink out an error code (4 blue blinks, followed by a pause). If more than one sensor is linked, the sensor heartbeats from all sensors must have stopped for the error warning to begin blinking.

PHOTOCELL OPERATION

- The **Ambient Setpoint** and **Photocell Operating Mode** are settings stored within the wall switch controller. For all photocell applications (e.g. on/off override), the wall switch controller receives the light level readings being transmitted every 15 seconds by wirelessly linked photocells. The controller will then turn off or on connected lighting in order to maximize energy savings while maintaining desired minimum light level.
- The setpoint value initially is established by the running the Auto-Setpoint calibration procedure that is built into the wireless photocell. Once initially determined, the setpoint can be changed at the wall switch controller by selecting from a list of values.
- The wireless wall switch controller will only listen to a single wireless photocell sensor. If more than one is wirelessly linked, the unit that last ran the auto-setpoint calibration procedure will be used.
- The photocell control algorithm compensates for the contribution of the controlled lighting to the overall light level of the space. This prevents lights from cycling back on shortly after they are switched off by the photocell operation.
- When the unit's **Photocell Operating Mode** is set to On/Off Operation or Inhibit Operation, there is a 45 second transition time after the ambient light level falls below the setpoint to when the connected lighting is switched on. During this transition time, the LED on the wall switch controller will be slowly blinking blue.
- When the unit's **Photocell Operating Mode** is set to On/Off Operation, there is a 5 minute transition time after the ambient light level surpasses the setpoint to when the connected lighting is switched off. During this transition time, the LED on the wall switch controller will be slowly blinking blue.
- Whenever lights are being held off due to the photocell, the blue LED will double blink every 15 seconds.

FCC INFORMATION (FCC ID: 2AVRY-SWX0001)

This device complies with Part 15 of the FCC Rules. Operation is subject to the following conditions:

1. This device may not cause harmful interference, and
2. This device must accept any interference received, including interference that may cause undesired operation

Changes and Modifications not expressly approved by BLP Technologies can void your authority to operate this equipment under Federal Communications Commission's rules.

In order to comply with FCC/ISED RF Exposure requirements, this device must be installed to provide at least 20 cm separation from the human body at all times.

This equipment has been tested and found to comply with the limits for a Class B digital device, pursuant to Part 15 of the FCC Rules. These limits are designed to provide reasonable protection against harmful interference in a residential installation. This equipment generates uses and can radiate radio frequency energy and, if not installed and used in accordance with the instructions, may cause harmful interference to radio communications. However, there is no guarantee that interference will not occur in a particular installation. If this equipment does cause harmful interference to radio or television reception, which can be determined by turning the equipment off and on, the user is encouraged to try to correct the interference by one of the following measures:

- Reorient or relocate the receiving antenna.
- Increase the separation between the equipment and receiver.
- Connect the equipment into an outlet on a circuit different from that to which the receiver is connected.
- Consult the dealer or an experienced radio/TV technician for help

ISED CANADA INFORMATION (IC: 26012-SWX0001)

This device contains licence-exempt transmitter(s)/receiver(s) that comply with Innovation, Science and Economic Development Canada's licence-exempt RSS(s). Operation is subject to the following two conditions:

1. This device may not cause interference.
2. This device must accept any interference, including interference that may cause undesired operation of the device.

In order to comply with FCC/ISED RF Exposure requirements, this device must be installed to provide at least 20 cm separation from the human body at all times.

L'émetteur/récepteur exempt de licence contenu dans le présent appareil est conforme aux CNR d'Innovation, Sciences et Développement économique Canada applicables aux appareils radio exempts de licence. L'exploitation est autorisée aux deux conditions suivantes :

1. L'appareil ne doit pas produire de brouillage;
2. L'appareil doit accepter tout brouillage radioélectrique subi, même si le brouillage est susceptible d'en compromettre le fonctionnement.
3. Afin de se conformer aux exigences d'exposition RF FCC / ISED, cet appareil doit être installé pour fournir au moins 20 cm de séparation du corps humain en tout temps

